



CURTI
INDUSTRIES

<< Always customer oriented through **Commitment and Passion** >>

Alessandro Curti
Chief Executive Officer

CURTI INDUSTRIES - STRUCTURE

TURNOVER (2014)

Total Turnover:
103 Million €

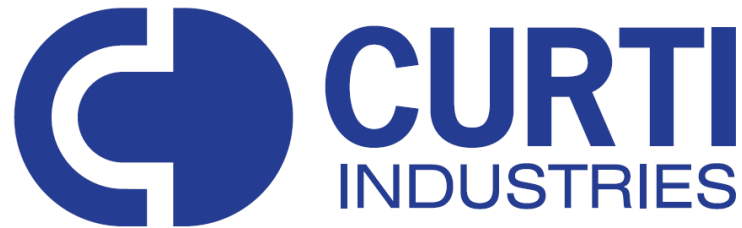

HEADCOUNT (2014)

Total Employees:
431

 **CURTI**
Parent Company:
9 subsidiaries

CURTI INDUSTRIES – STRUCTURE & SHAREHOLDING

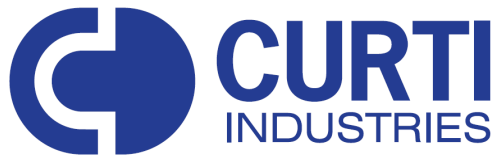

BLISTER PACKAGING, HORIZONTAL
CARTONERS & CASE PACKERS

CURTIMET

SUBCONTRACTING OF MECHANICAL
PARTS & UNITS

FibreForm Packaging

INNOVATIVE PACKAGING SOLUTION
BY FORMABLE PAPER



SPECIAL MACHINE TOOL,
AUTOMATION & SUBCONTRACTING

COGNETEX

UNDISPUTED LEADER OF THE
GLOBAL TEXTILE MACHINERY
MARKET



SPECIAL MACHINE TOOL,
AUTOMATION & SUBCONTRACTING



ULTRA-LIGHT AIRCRAFT'S ENGINES



FORCE MEASUREMENT TECHNOLOGY



STRATEGIC POOL OF ENGINEERS &
DESIGNERS

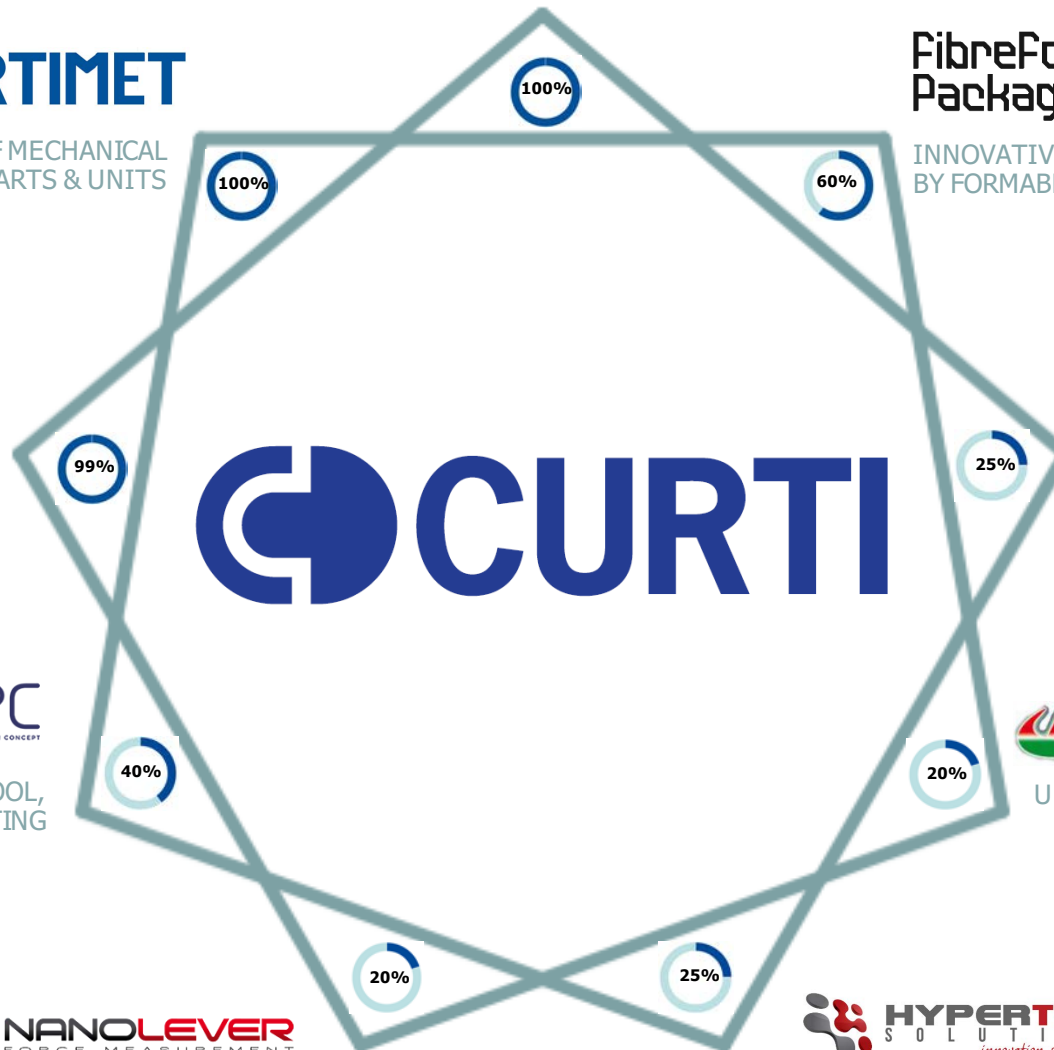

CURTI INDUSTRIES - VALUES

Thanks to the

WORLD CLASS MANUFACTURING,

CURTI has founded its processes on strong pillars,

from MANUFACTURING to

HUMAN RESOURCES MANAGEMENT

ENTREPRENEURIAL IDEAS

and

BUSINESS DIVERSIFICATION

have led CURTI to a
substantial & steady growth

PEOPLE

Are the most important company asset:
Commitment, Involvement and Passion are
daily pursued and encouraged





A close-up photograph of a blue fabric, likely a uniform, featuring an embroidered logo and the word "CURTI". The logo is a stylized blue circle with a white arrow pointing to the right. The word "CURTI" is embroidered in a blue, sans-serif font to the right of the logo.

 **CURTI**



Established in **1955**,
CURTI Costruzioni Meccaniche S.p.A.

is a family run company mainly operating in different industries:

220 employees, **6** Strategic Business Units



OWNERSHIP



ALESSANDRO
CURTI

Chief Executive Officer



CLAUDIA
CURTI

President & Chief Financial Officer



TURNOVER & TREND

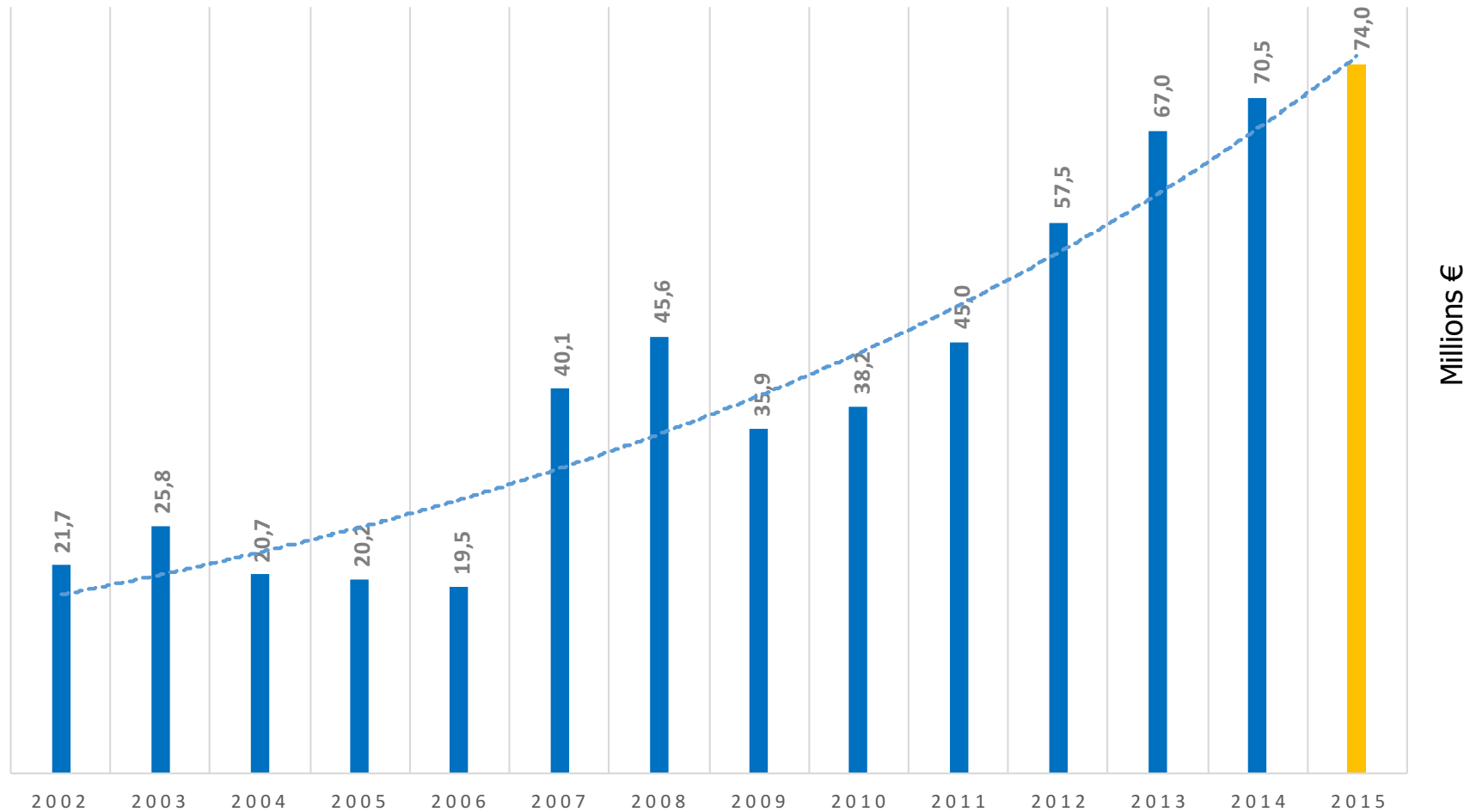

QUALITY ACHIEVEMENT AWARDS



1986

Second Part AQAP 4
Certification

Certification
ISO 9001 e WCM introduction



2007



Certification EN 9100 (Aeronautic and Defence)



Accreditation NADCAP
(NDT PT – MT)



2014



DIN 2303 Defence
Welding Certification
ISO 3834-2 Welding
Certification

BUSINESS UNITS

 **CURTI**
CO-ENGINEERING



 **CURTI**
AEROSPACE



 **CURTI**
PACKAGING



 **CURTI**

 **CURTI**
WIRE PROCESSING



 **CURTI**
TEXTILE



 **CURTI**
ENERGY





 **CURTI**
AEROSPACE

OUR SKILLS

- Long and strong experience in **co-design, co-development,** and manufacturing special and customized solutions
- Long experience in machining and welding titanium material and special light alloys
- In-house Quality Lab equipped with the state-of-the-art technology for measuring and testing

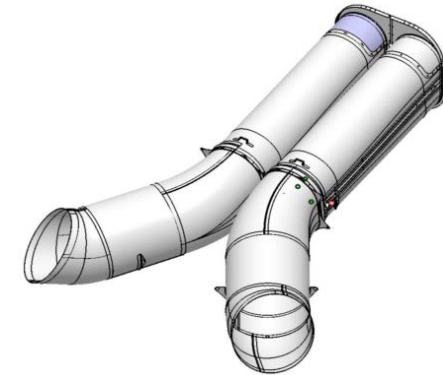

OUR DAILY COMMITMENT

- To support our Customers in designing and engineering activity
- To provide our Customers with the state-of-the-art technologies in manufacturing
- To supply completely tested machines/modules

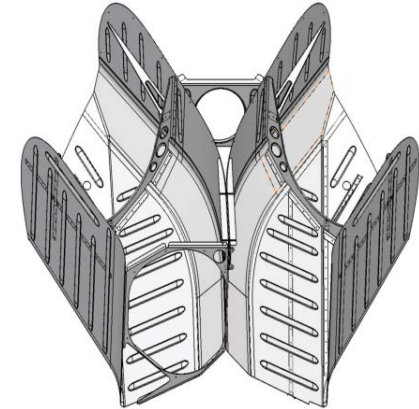

OUR NEW CHALLENGE

Development and manufacturing of an ultralight helicopter within 2015





 **CURTI**
CO-ENGINEERING

PARTNERSHIP WITH TETRAPAK

A great expertise as solution providers allows CURTI to establish long term relationship with market leader customers

Our partnership with TETRAPAK is the most explicative and clear evidence of our Co-Engineering business unit



- Co-designing and complete manufacturing of capping machine mod. **CAP30** (including supply chain management)
- Dedicated assembling line with a production capability up to 10 machines per week
- Final in-house test and delivery to **TETRA PAK's customers**



- Manufacturing and assembling of machine body **A3 Platform**



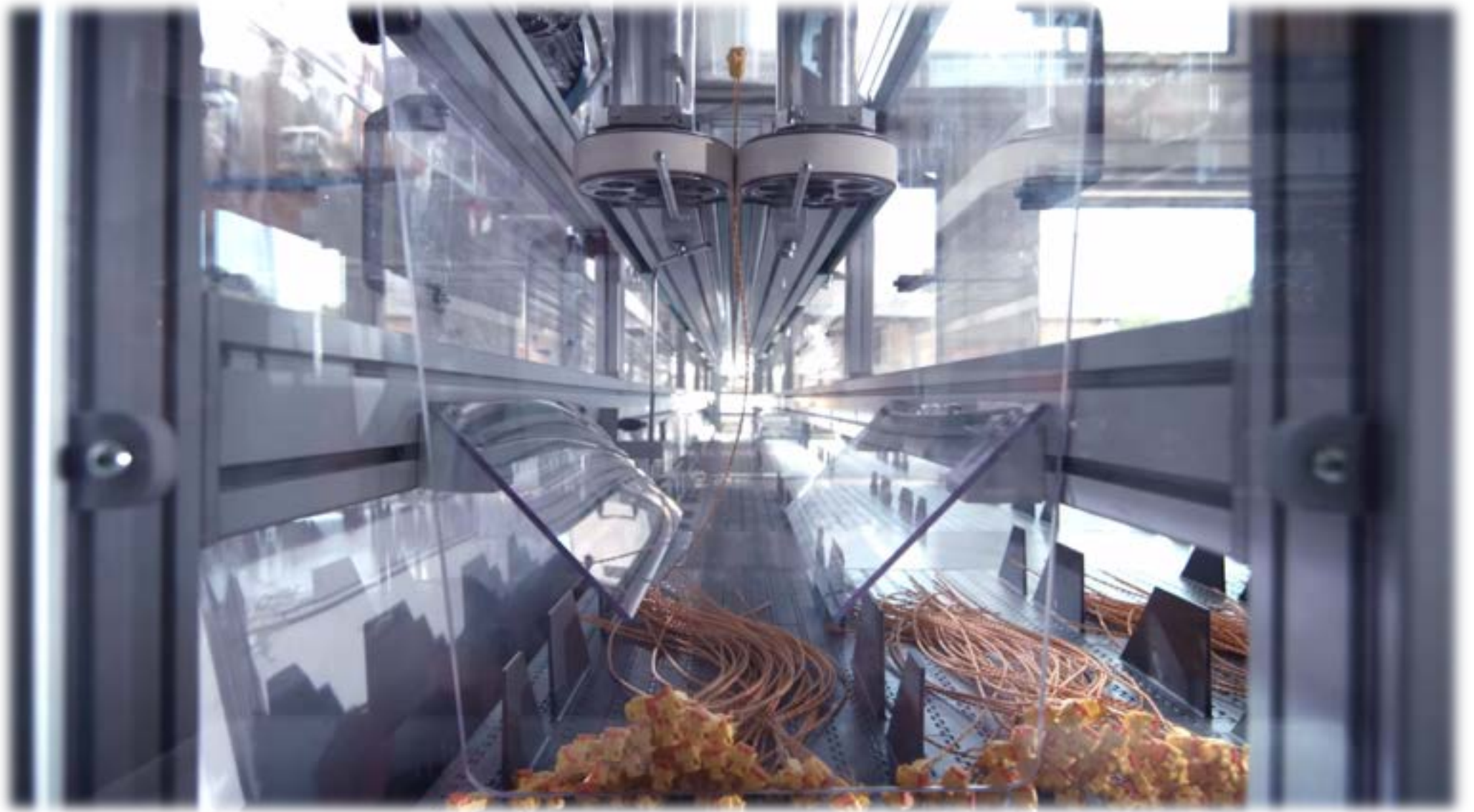

 **CURTI**
WIRE PROCESSING

CABLES & HARNESS MANUFACTURING

Since 1994, CURTI WIRE PROCESSING supplies fully automated lines and semi-automatic machines for wire and cable processing

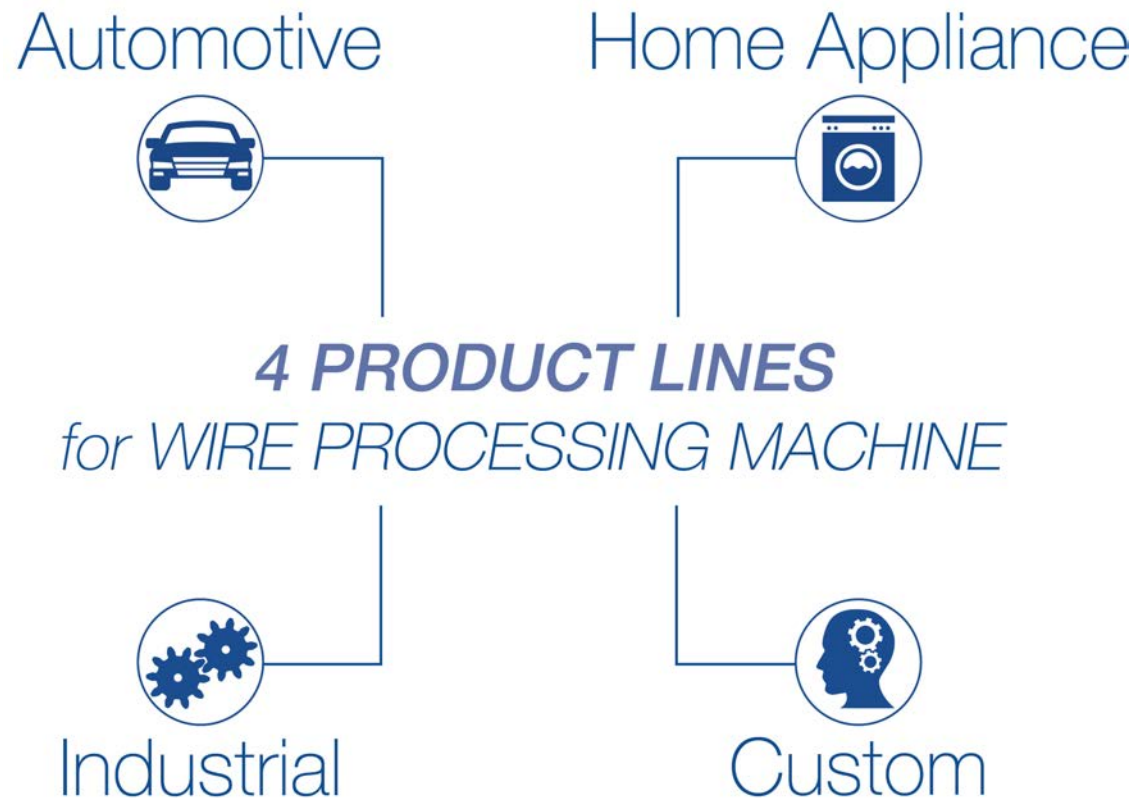



AUTOMOTIVE



Premium supplier of fully automated lines for DELPHI AUTOMOTIVE PLC
able to process in-line **Airbag - Squib Connectors**

Automation also for **antenna cables, sensors, horns,
battery cables and harness modules**





HOME APPLIANCE

Undisputed leader, worldwide, for transfer lines and equipment for **Power Cords and IDC harness modules**





INDUSTRIAL



Makfil srl was acquired in 2010, increasing the product portfolio through a full range of semiautomatic and automatic machine for **cutting, stripping, crimping and tinning** **single-core, multicore, flat, twisted and coaxial cables**



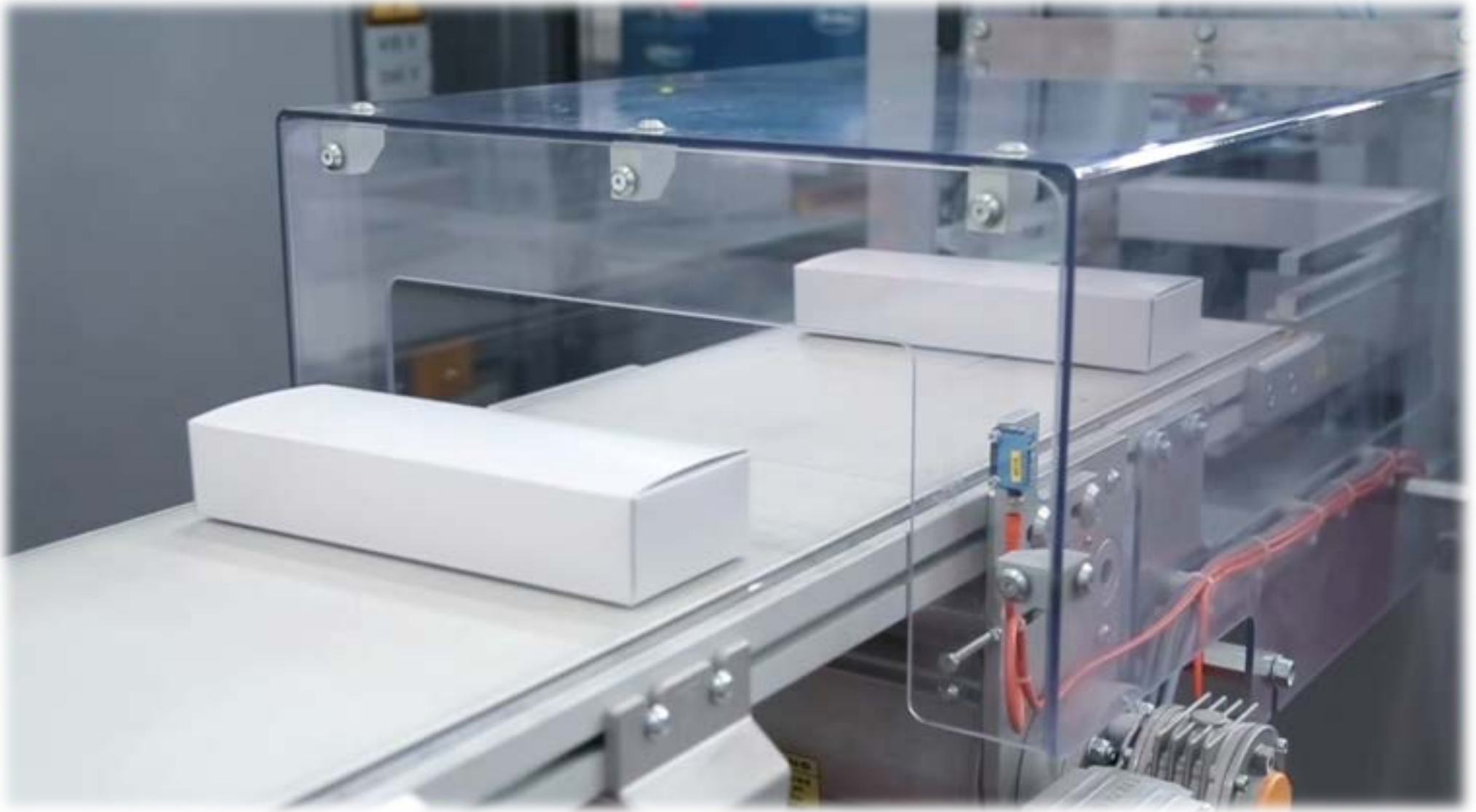

 **CURTI**
PACKAGING

END OF LINE PACKAGING

Design and supply of innovative packaging solutions for **pharmaceutical** and **food industries**



VERTICAL CARTONERS

Food

Designed to process a wide variety of dried and powdery products



Pharma

Designed to comply with the strict pharma industry regulations.



- Entirely made of **paperboard**
- Totally recyclable



CASE PACKERS & PALLETIZERS

Specifically developed to handle a great variety of products, to meet the pharma and food market requirements





 **CURTI**
ENERGY

ENVIRONMENT PROTECTION

Since 2006, CURTI ENERGY provides innovative solutions for the energy saving and the energy production by green and alternative sources



ENERGY CONSERVATION

- **BIOGAS PRODUCTION PLANTS**
- **COGENERATION PLANTS**
(internal combustion engines and gas turbines)
- **FLUE GAS AND AIR TREATMENT**
(elimination of solid particles and pollutants)
- **REMOVAL OF SOLID PARTICLES AND OTHER POLLUTANTS**
(wet filters to be used in toxic waste treatment plants)
- **INDOOR AIR TREATMENT**
(to remove oil and emulsion vapours from machine tools)
- **CONSTRUCTION OF A COMPLETE PYROLYSIS PLANT FOR SCRAP TYRES**





CURTI
INDUSTRIES

SUBSIDIARY COMPANIES

FIBERFORM PACKAGING: JOINT-VENTURE

BILLERUDKORSNÄS



FibreForm
Packaging 

 **CURTI**
CURTI COSTRUZIONI MECCANICHE S.p.A.



FibreForm Packaging offers a complete solution called **FreeFormPack®** which is based on the proprietary stretchable BillerudKorsnäs FibreForm® paper and formed in the proprietary FreeFormPack® Machine by Curti.



FIBERFORM PACKAGING: JOINT-VENTURE

FreeFormPack® is the worlds first cylindrical Formable Paper Package, which lets the customer create premium and tactile packages with unique shapes, silhouettes and textures, entirely made from renewable paper!

 <http://freeformpack.com/>



WHOLLY OWNED SUBSIDIARY COMPANIES



Newco derived from the previous 

Automatic machines for blister and cartons for pharmaceutical, herborist and cosmetic fields.



 <http://famartecsrl.com/>



Manufacturing of special tooling machine.



 <http://cmasrl.net/>



Production plant located in Poland, specialized in the subcontracting of mechanical parts and units.

SUBSIDIARY COMPANIES



NPC has been created as a direct response to the Tetra Pak initiative to have integrated service from suppliers.

Complete package Supply of Groups and/or fully assembled machines.

Assembling and testing of complete machines and lines for many business sectors

NPC Space Mind Division provides solutions for nanosatellite technology in cooperation with UNIBO and Università La Sapienza Roma



<http://npcitaly.com/>

COGNETEX

Cognetex is a brand present for over 60 years, the undisputed leader of the global textile machinery market.

The high degree of specialization and experience in this area, has helped to make Cognetex synonymous of quality and reliability.



<http://cognetex.com/>

SUBSIDIARY COMPANIES



R&D Center
Engineering & Designing

 <http://hypertecs.it/>



Force transductions and weighing for nanometric measurement
in pharmaceutical and aerospace industry

 <http://nanolever.com/>

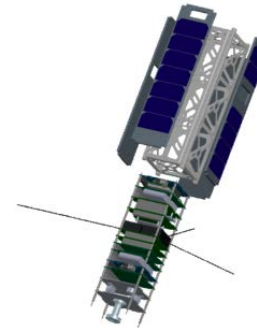

Maintenance for rotax engines and sales of ultralight aircrafts
(Aeroprakt & Atec)

 <http://fly-safe.it/>



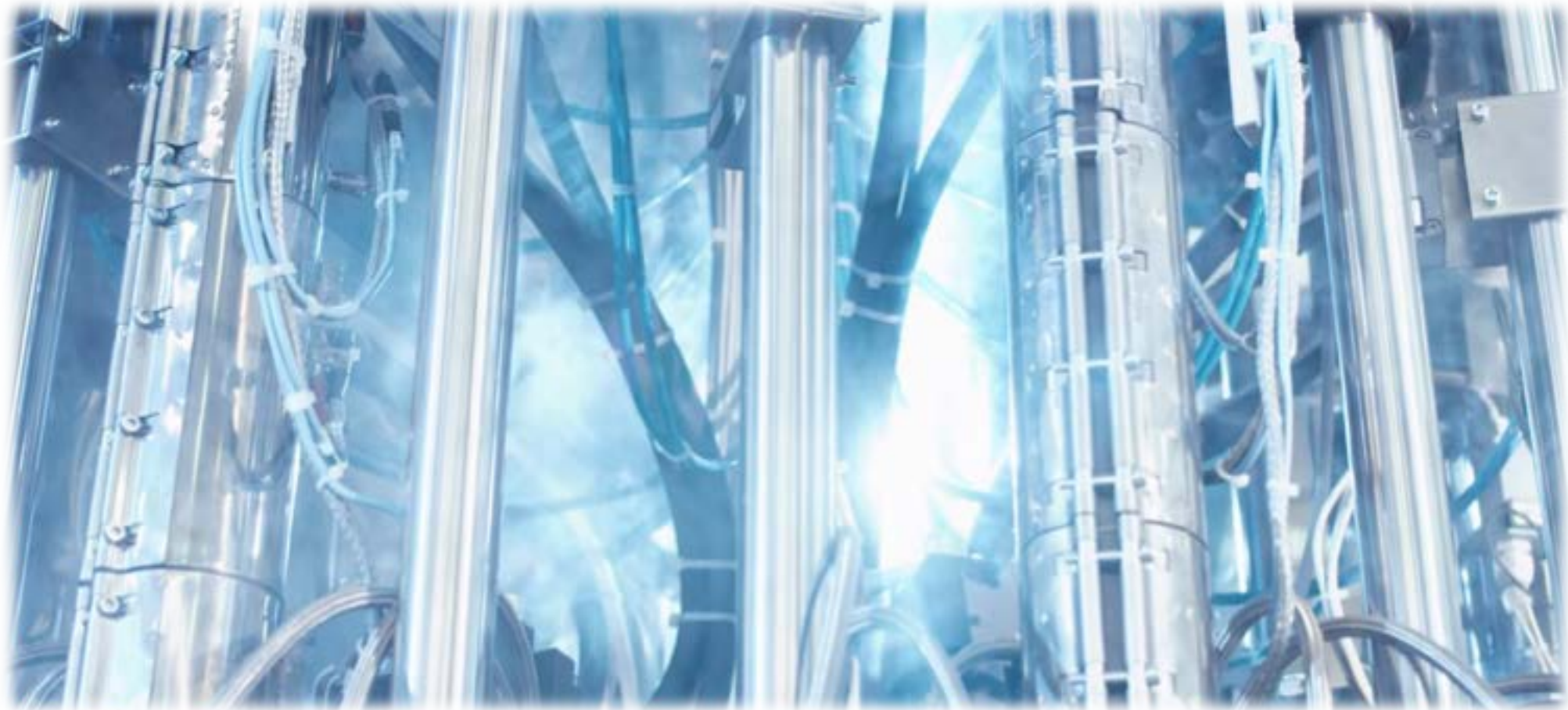

**THANK YOU
FOR
YOUR
ATTENTION!**